

Four-Port, Controlled Valves

PVT1		RC 1/4 ~ 1/2
PVT406K	Standard type	RC 3/4
PVT410K		RC 1
PVT1M	With lock mechanism type	RC 3/8 · 1/2
PVT1L	Bottom-port type	RC 3/8 · 1/2
PVT406L		RC 3/4
PVT410L		RC 1

These are 3 position control valves which operated manually.

JIS Symbol

See Model Code section.

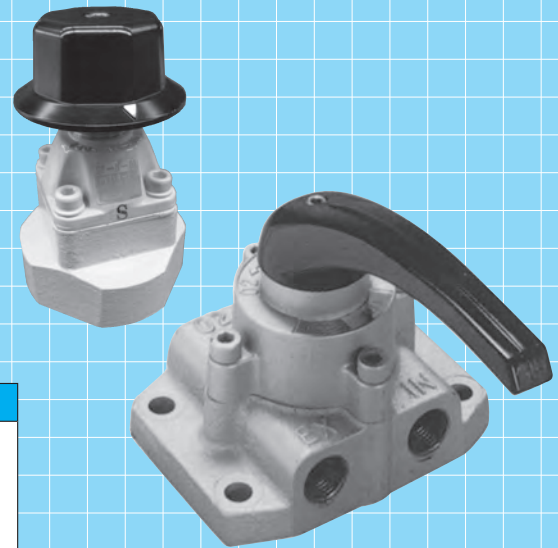

Specifications

Model code	Standard type	PVT1			PVT406K	PVT410K
	Type with lock mechanism	PVT1M				
	Bottom-port type	※	PVT1L			PVT406L
Port size		8A	10A	15A	20A	25A
		Rc1/4	Rc3/8	Rc1/2	Rc3/4	Rc1
Effective sectional area		5.7mm ²	50mm ²	60mm ²	100mm ²	
Operating angle		90°	120°			
Operating pressure		0 ~ 0.7MPa				
Proof pressure		1.05MPa				
Allowable valve leakage		50cm ³ /min (ANR) . [at 0.5MPa]				
Operating temperature		- 20 ~ 60°C	5 ~ 60°C			
Mass		2.0kg	2.6kg		7.2kg	8.0kg

● For specifications other than those listed above, please contact us.

※ Note that size 8A or PVT1 is of the bottom pipe type.

● In the event of use in high dry air above dew point - 40°C , please contact us.

Model Code

When ordering, specify the model as follows:

Standard type

Rc 1/4

PVT1 **1** **2** -8A
 • Handle shape • Valve type

Rc 3/8 ~ 1/2

PVT1 **2** - **5**
 • Valve type • Port size

Rc 3/4

PVT406K **3** -20A
 • Valve type

Rc 1

PVT410K **3** -25A
 • Valve type

Type with lock mechanism

Rc 3/8 ~ 1/2

PVT1M **3** - **4** - **5**
 • Valve type • Stopper position • Port size

Bottom-port type

Rc 3/8 ~ 1/2

PVT1L **3** - **5**
 • Valve type • Port size

Rc 3/4

PVT406L **3** -20A
 • Valve type

Rc 1

PVT410L **3** -25A
 • Valve type

1 Handle shape	
Round handle	No entry
Rod handle	B

• Round handle is not available for 10A and 15A.

4 Stopper position	
Neutral	1
Both ends	2
All positions	3

2 Valve type			
Closed center	8A		No entry
	10A • 15A		
Open center	8A		R
	10A • 15A		
Exhaust Block	8A		E

3 Valve type		
Closed center		No entry
Open center		R

5 Port size	
Rc3/8	10A
Rc1/2	15A



Outside Dimensions

Standard type

PVT1-8A

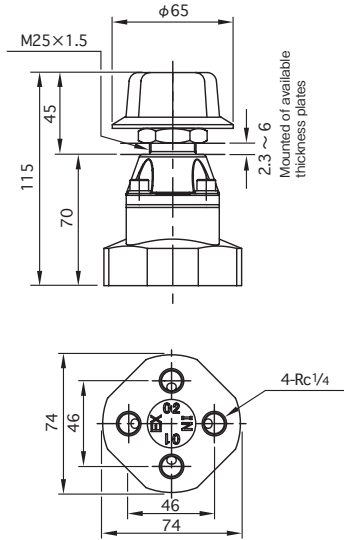

PVT1B-8A

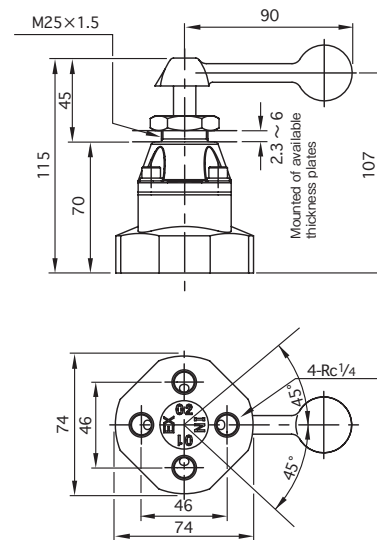

Outside Dimensions

Standard type

PVT1-10A · 15A

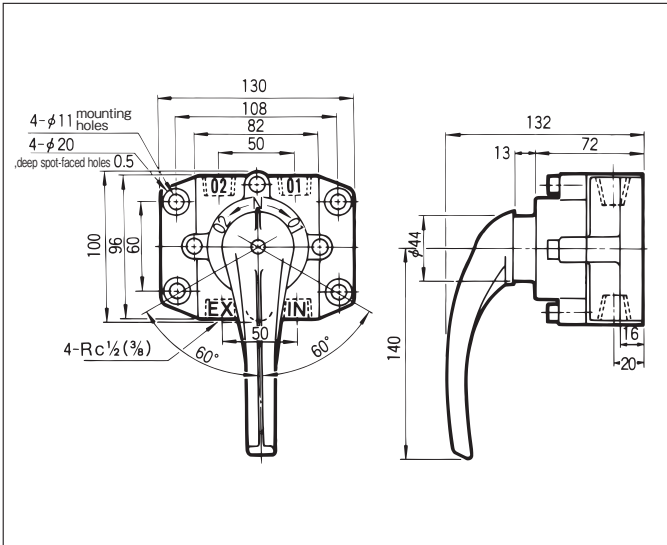

Type with lock mechanism

PVT1M-10A · 15A

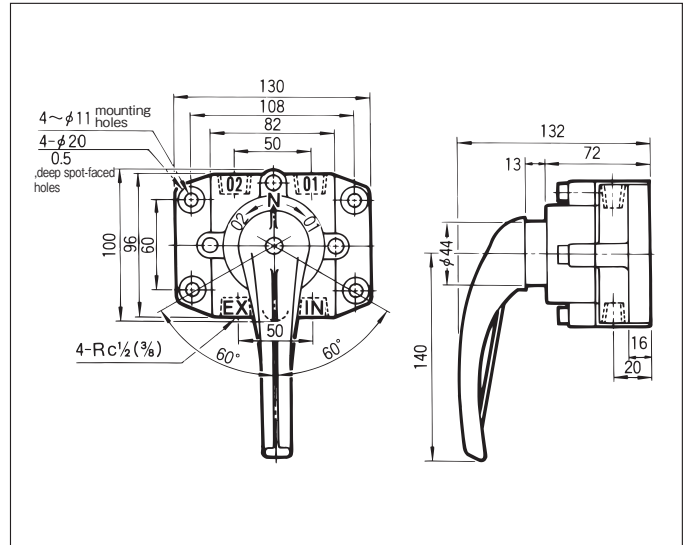

PVT406K-20A

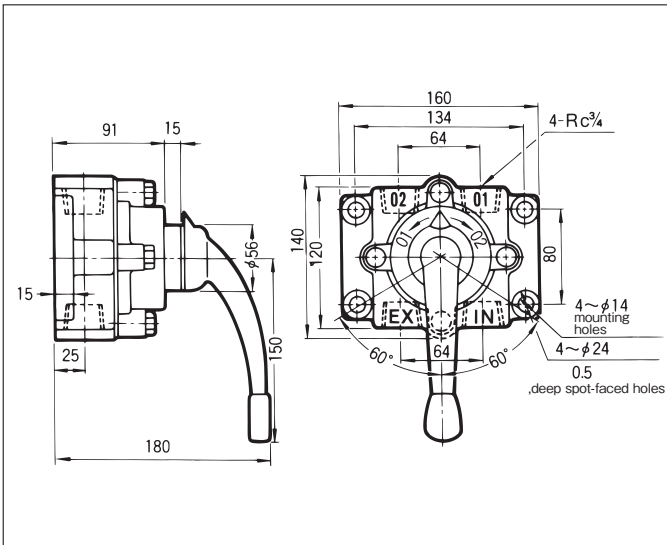

PVT410K-25A

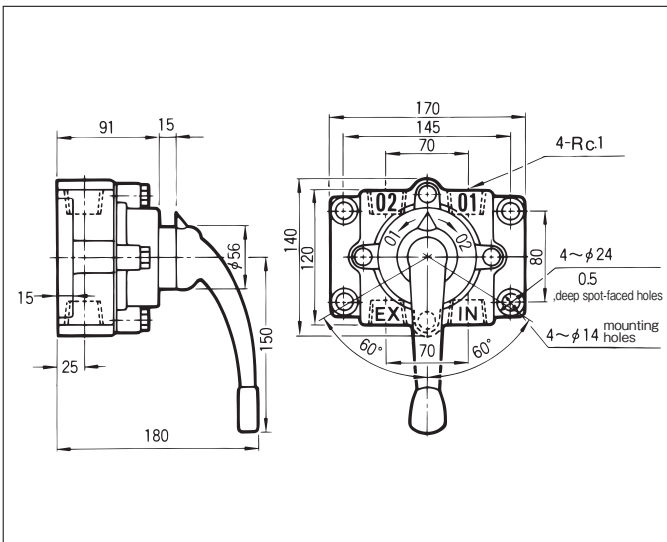



Outside Dimensions

Bottom-port type

PVT1L-10A · 15A

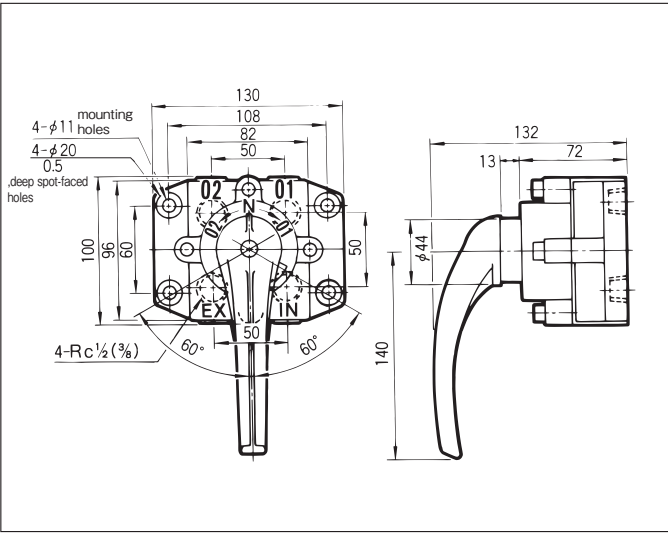

PVT406L-20A

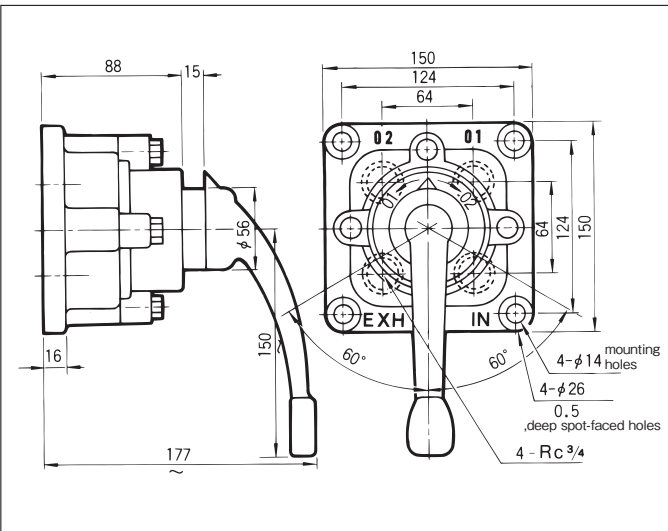

PVT410L-25A

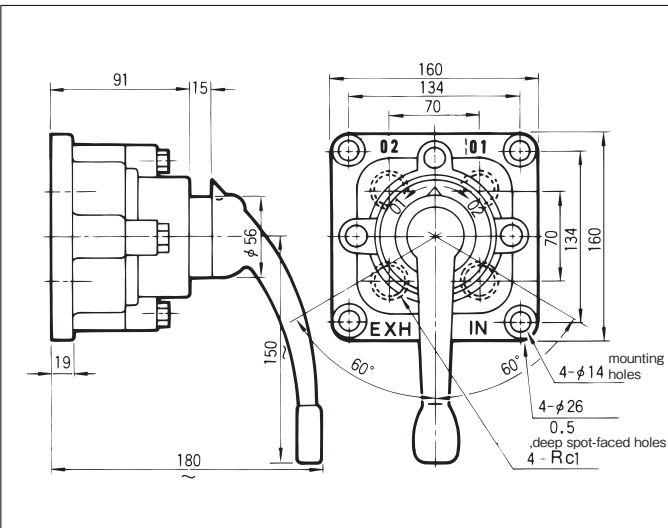

Performance Tables

Flow characteristics graphs

Standard and With lock mechanism , Bottom-port type

PVT1-8A

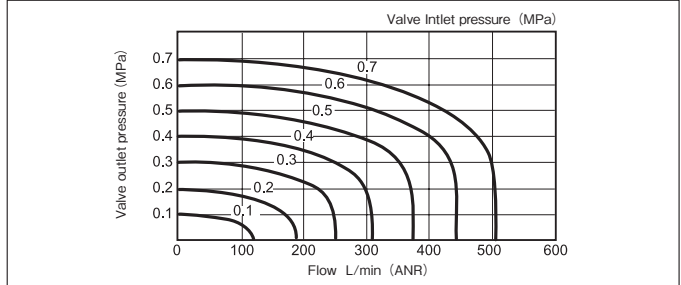

PVT1-10A

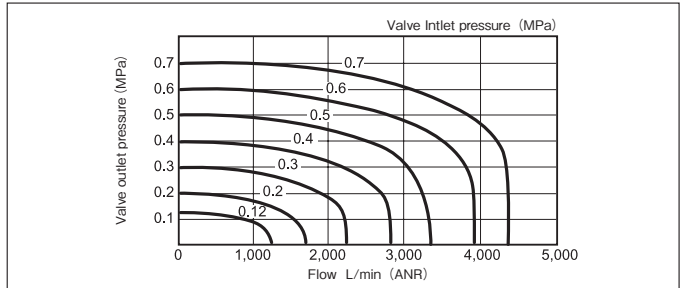

PVT1-15A

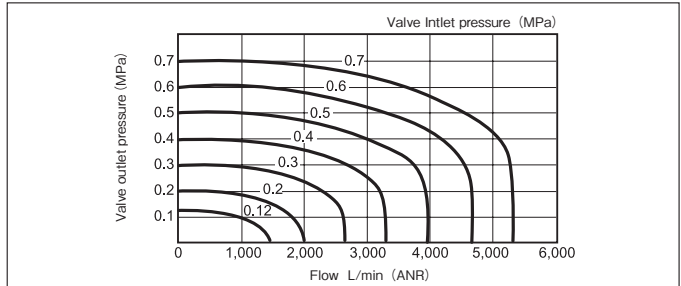

PVT406K-20A

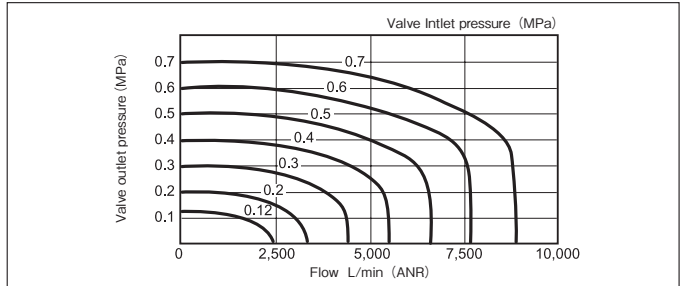

PVT410K-25A

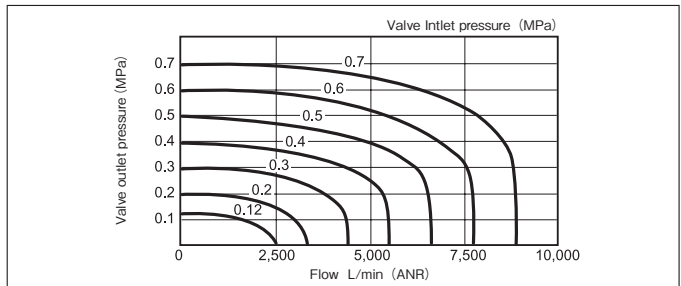

Operating Instructions

1 Installation

- **Clean the piping.**

Flash the piping thoroughly after laying. Use pipes with an inside surface plated with zinc.

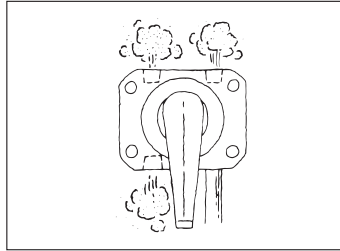

- **Fluid.**

Since dirt and wastes in the fluid hinder proper functioning of the valve and shorten its service life, use clean air as the fluid.

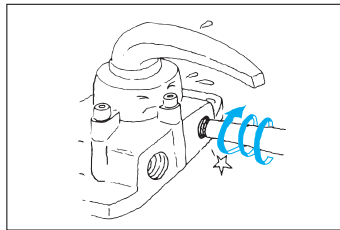

- **Do not force port.**

Limit the number of pipe threads screwed into the valve to four or five for any of sizes 8A to 25A (Rc1/4 "to 1") .

If the pipe is forced to enter the valve beyond that point, the valve body may be cracked, and leakage or malfunctioning result.

- If valves other than the type with a lock mechanism are to be installed and used vertically, please contact us.

2 Before use

- **Conversion to a threeport valve.**

If either of the two OUT ports is plugged, the valve can be used as a three-way, directional control valve.

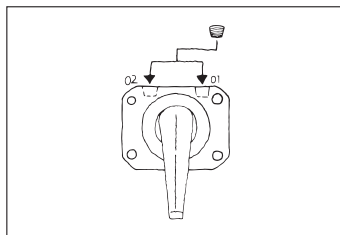

- **Leakage from the disc.**

Since a disc is fitted in the valve, a small amount of leakage may occur due to deformation at installation or from long periods of use, etc. However, this will cause no problem in normal use of the valve.

CHECK VALVES

CV3·CV1 Standard type RC 1/4 ~ 2

The check valve permits only one-way air flow and prevents reverse flow. Konan's check valves are designed for low cracking pressure and very low resistance to air.

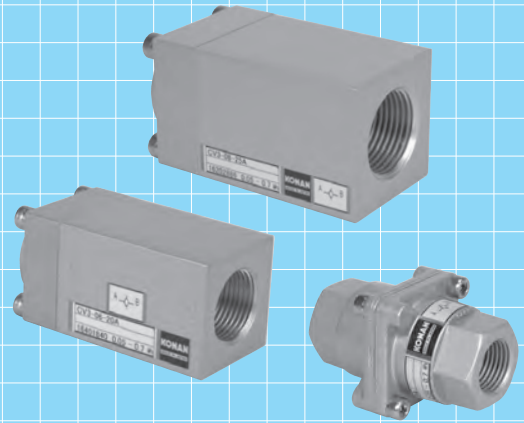
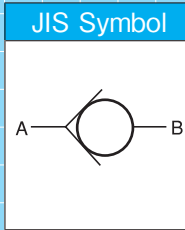

Model Code

When ordering, specify the model as follows:

Standard type

Rc 1/4 ~ 1/2	CV3	①	-04-	②	-	④
		● Corrosion-resistant		● Port size		● Operating temperature range
Rc 3/4	CV3	①	-06-	20A	-	④
		● Corrosion-resistant				● Operating temperature range
Rc 1	CV3	①	-08-	25A	-	④
		● Corrosion-resistant				● Operating temperature range
Rc 1_1/4 ~ 2	CV1	-	③			
			● Port size			

① Corrosion-resistant

- Portions that are exposed to outside weather conditions are corrosion-resistant coating and the exposed bolts and nuts are stainless steel.

Standard	No entry
Corrosion-resistant type	S

② Port size

Rc1/4	8A
Rc3/8	10A
Rc1/2	15A

③ Port size

Rc1_1/4	32A
Rc1_1/2	40A
Rc 2	50A

④ Operating temperature range

General purpose	- 20 ~ 60°C	No entry
Heat-resistant	5 ~ 100°C	HT
Freeze-resistant	- 40 ~ 45°C	LT

- For corrosion, freeze resistant type, allow some margin for delivery.
- In operating temperatures of 5°C or less, provide adequate measures against freezing.

Specifications

Model code	CV3-04			CV3-06	CV3-08	CV1		
Port size	8A	10A	15A	20A	25A	32A	40A	50A
	Rc1/4	Rc3/8	Rc1/2	Rc3/4	Rc1	Rc1 1/4	Rc1 1/2	Rc2
Effective sectional area	40mm ²	63mm ²	94mm ²	155mm ²	210mm ²	528mm ²		1,007mm ²
Operating pressure	0.05 ~ 0.7MPa					0.1 ~ 0.7MPa		
Cracking pressure	0.01MPa or less							
Proof pressure	1.05MPa							
Operating temperature	General purpose		- 20 ~ 60°C			5 ~ 60°C		
	Heat-resistant		5 ~ 100°C					
	Freeze-resistant		- 40 ~ 45°C					
Mass	0.13kg			0.27kg	0.45kg	1.0kg		2.2kg

- For specifications other than those listed above, please contact us.
- In the event of use in high dry air above dew point - 40°C, please contact us

Operation

Standard type CV3 — 04 — 15A

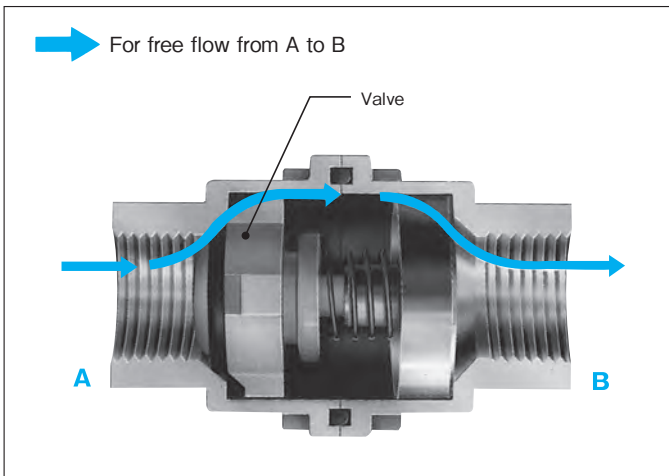

● For flow from ports A to B (free flow)

When air entering at port A exceeds the cracking pressure of the valve, the air forces the valve open and flows to port B.

● For flow from ports B to A (controlled flow)

The air pressure, together with the spring force, moves the valve in the closing direction, and the air entering port B is blocked.

Outside Dimensions

Standard type

CV3-04-8A · 10A · 15A

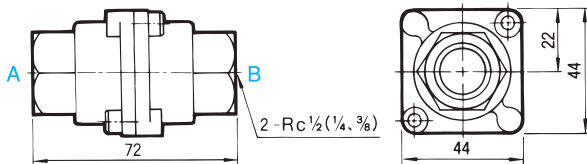

CV1-32A · 40A

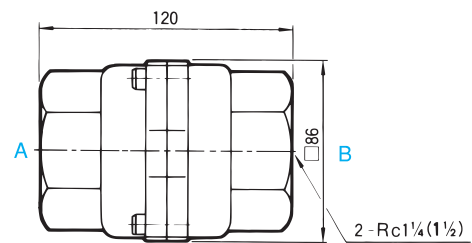

CV3-06-20A CV3-08-25A

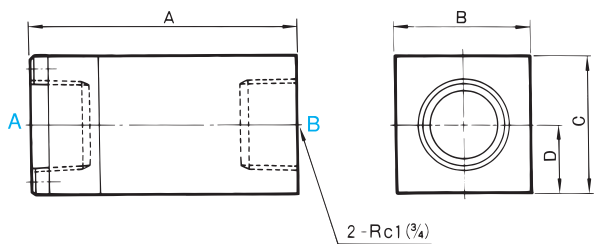

Units : mm

Size	20A	25A
A	80	95
B	40	50
C	40	50
D	20	25

CV1-50A

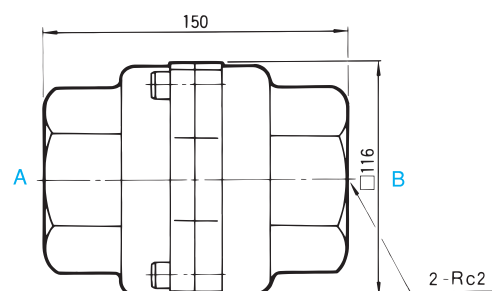



Performance Tables

Flow characteristics graphs (from ports A to B)

Standard type

CV3-04-8A

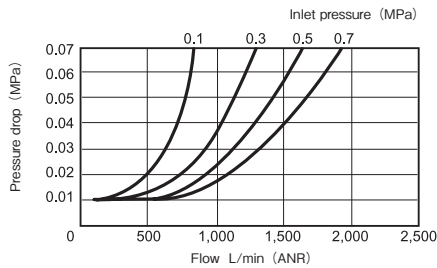

CV1-32A · 40A

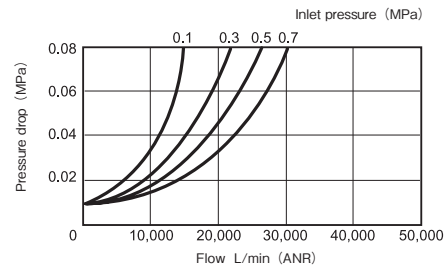

CV3-04-10A

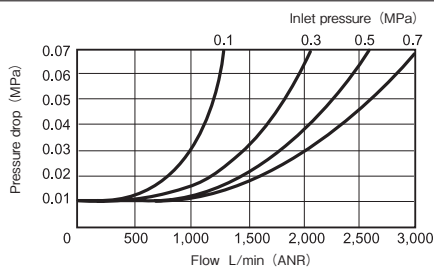

CV1-50A

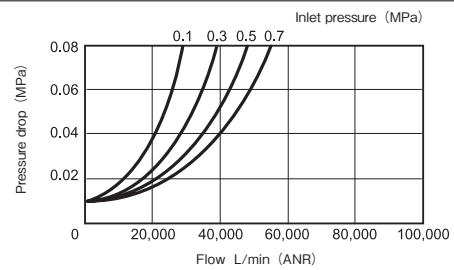

CV3-04-15A

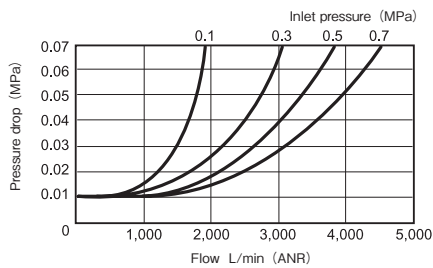

Operating Instructions

1 Varying pressures

- Note that for a low operating pressure, the flow is very small, and that for fluids that are subject to great pressure fluctuations, the valve may vibrate noticeably.

CV3-06-20A

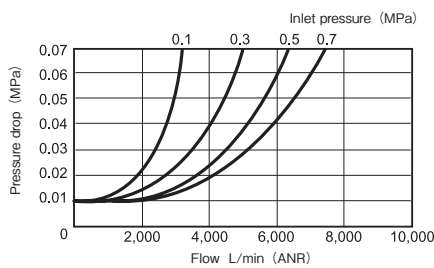

2 Fluid

- Dirt, wastes, etc. in the fluid may cause malfunctioning. Use only with clean fluids.

CV3-08-25A

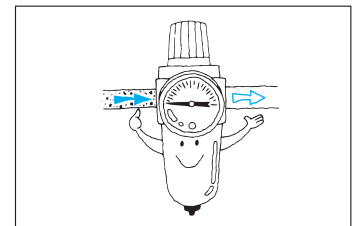
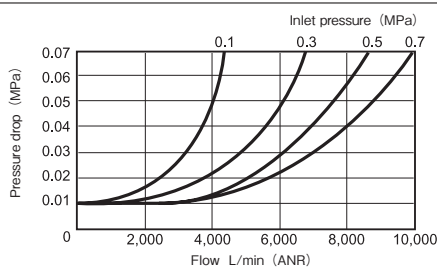

Pilot-Operated CHECK VALVES

CVP2 Standard type $Rc \frac{3}{8} \sim 1$

This is a check valve with a check release (reverse flow) mechanism that is operated by a signal pressure.

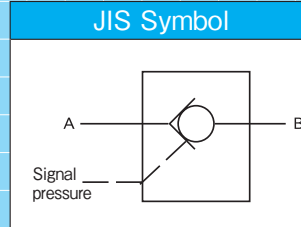

Model Code When ordering, specify the model as follows:

Standard type

Rc 3/8 ~ 1/2

CVP2 - 04 - 1

• Port size

Rc 3/4 ~ 1

CVP2 - 08 - 2

• Port size

1 Port size	
Rc3/8	10A
Rc1/2	15A

2 Port size	
Rc3/4	20A
Rc1	25A

Specifications

Model code	CVP2-04		CVP2-08	
	Port size	10A Rc3/8	15A Rc1/2	20A Rc3/4
Effective sectional area	30mm ²	49mm ²	83mm ²	137mm ²
Operating pressure	0.1 ~ 0.7MPa			
Signal pressure	0.12 ~ 0.7MPa Signal pressure \geq Pressure of the fluid \times 1/2			
Cracking pressure	0.01MPa or less			
Proof pressure	1.05MPa			
Operating temperature	-20 ~ 60°C (For use below 5°C ,provide adequate measures against freezing.)			
Mass	1.4kg		2.9kg	

- For specifications other than those listed above, please contact us.
- In the event of use in high dry air above dew point - 40°C ,please contact us.



Outside Dimensions

Standard type

CVP2-04-10A · 15A

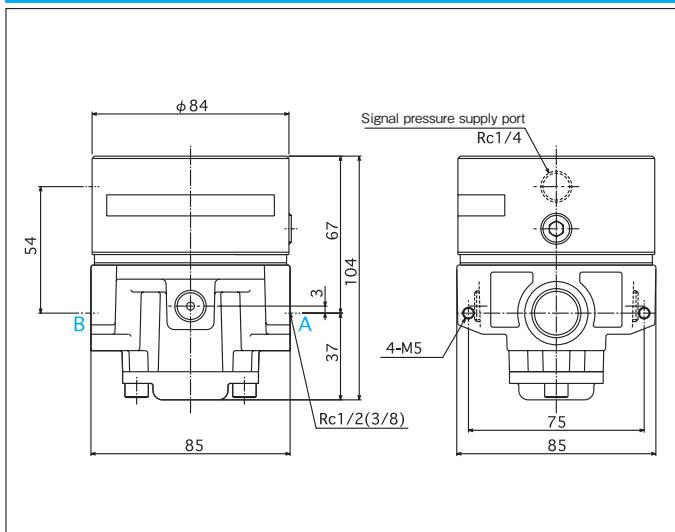

CVP2-08-20A · 25A

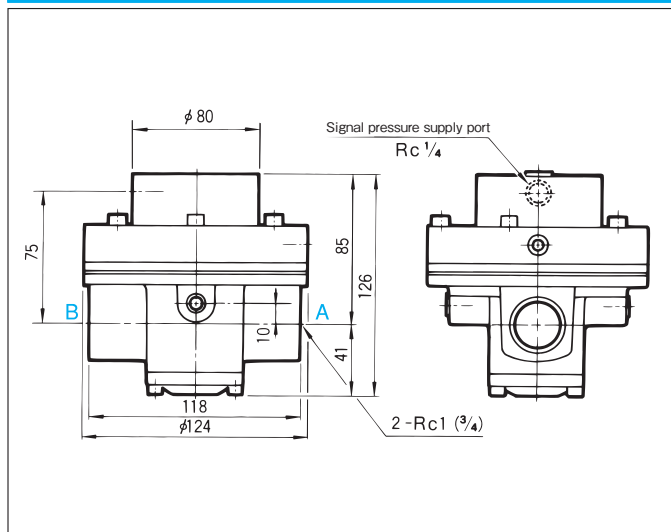

Performance Tables

Flow characteristics graphs (from ports A to B)

CVP2-04-10A

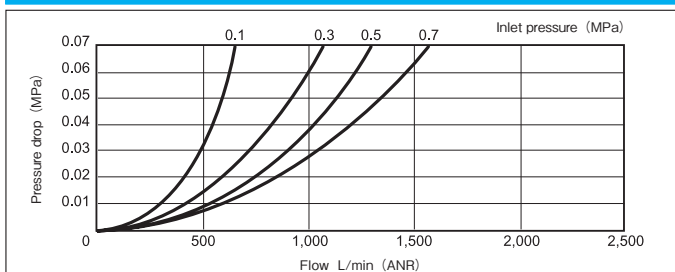

CVP2-08-25A

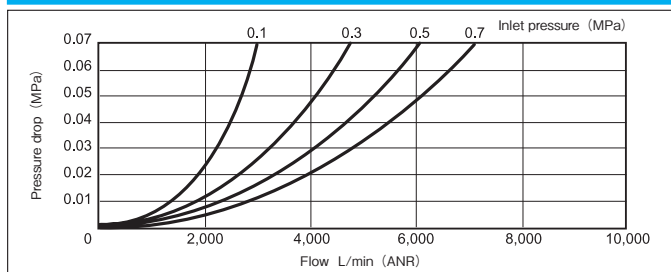

CVP2-04-15A

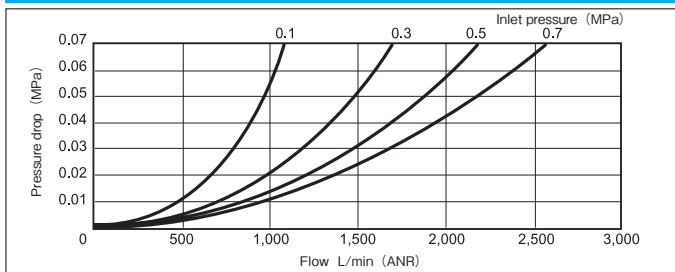

CVP2-08-20A

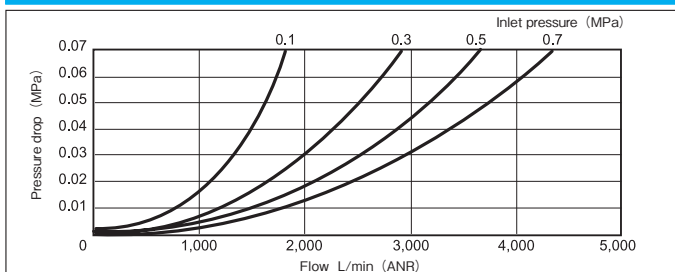

Operating Instructions

1 Varying pressures

- Note that for a low operating pressure, the flow is very small, and that for fluids that are subject to great pressure fluctuations, the valve may vibrate noticeably.

2 Fluid

- Dirt, wastes, etc. in the fluid may cause malfunctioning. Use only with clean fluids.

SHUTTLE VALVES

CVT3

Standard type

Rc 1/4 ~ 1 1/2

JIS Symbol

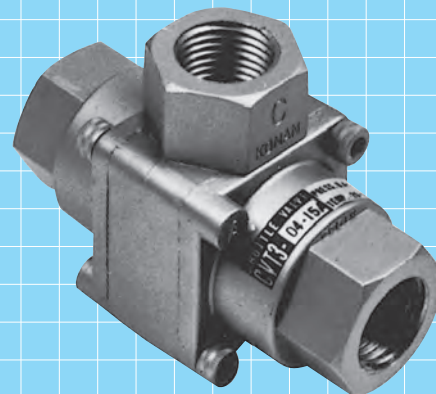
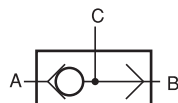

A shuttle valve has two supply ports and one discharge port. When air pressure is admitted through one supply port, the other supply port is closed and the air pressure is transferred to the discharge port.

Model Code

When ordering, specify the model as follows:

Standard type

Rc 1/4 ~ 1/2

CVT3 1 - **04** - 2 - 4 - 5

• Corrosion-resistant • Port size • Operating temperature range • Bracket

Rc 3/4

CVT3 1 - **06** - **20A** - 4

• Corrosion-resistant • Operating temperature range

Rc 1

CVT3 1 - **08** - **25A** - 4

• Corrosion-resistant • Operating temperature range

Rc 1 1/4 ~ 1 1/2

CVT3 1 - **14** - 3

• Corrosion-resistant • Port size

1 Corrosion-resistant

- Portions that are exposed to outside weather conditions are corrosion-resistant coating and the exposed bolts, nuts and brackets* are stainless steel.
- * The bracket is an option of only 04 size.

Standard	No entry
Corrosion-resistant type	S

2 Port size

Rc1/4	8A
Rc3/8	10A
Rc1/2	15A

3 Port size

Rc1 1/4	32A
Rc1 1/2	40A

4 Operating temperature range

General purpose	-20 ~ 60°C	No entry
Heat-resistant	5 ~ 100°C	HT
Freeze-resistant	-40 ~ 45°C	LT

- For corrosion, freeze resistant type, allow some margin for delivery.
- In operating temperatures of 5°C or less, provide adequate measures against freezing.

5 Bracket

Without	No entry
With	BR

- Bracket is not mounted but appended with valves.

Specifications

Model code	CVT3-04			CVT3-06	CVT3-08	CVT3-14	
Port size	8A	10A	15A	20A	25A	32A	40A
	Rc1/4	Rc3/8	Rc1/2	Rc3/4	Rc1	Rc1 1/4	Rc1 1/2
Effective sectional area	44mm ²	65mm ²	95mm ²	116mm ²	185mm ²	350mm ²	400mm ²
Operating pressure	0.04 ~ 0.7MPa						
Proof pressure	1.05MPa						
Minimum operating pressure differential	0.01MPa					0.02MPa	
Operating temperature	-20 ~ 60°C						
Mass	0.22kg			0.31kg	0.52kg	1.5kg	

- For specifications other than those listed above, please contact us.
- In the event of use in high dry air above dew point - 40°C, please contact us.



Shuttle Valves

Operation

Standard type CVT3 — 04 — 15A

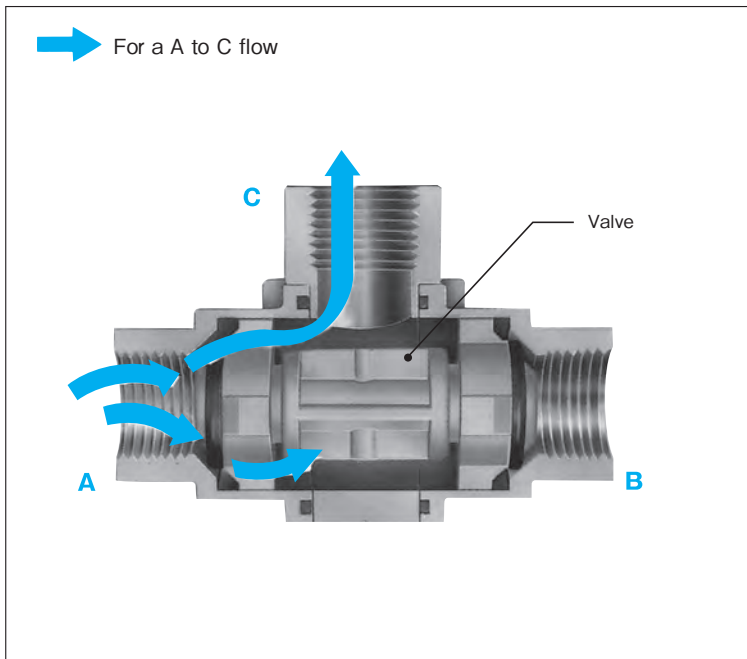

- 1 When air enters port A, it moves the valve and closes port B and then flows to port C.
- 2 When air enters port B, the air pressure from port B moves the valve and closes port A and then flows to port C.
Be sure to place ports A and B in a discharge condition when air pressure is furnished via ports B and A, respectively.

Outside Dimensions

CVT3-04-8A • 10A • 15A

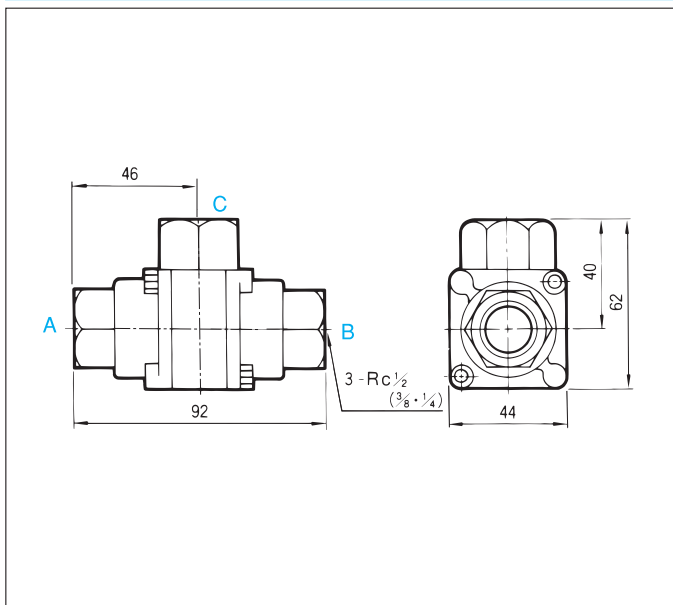

CVT3-06-20A CVT3-08-25A CVT3-14-32A • 40A

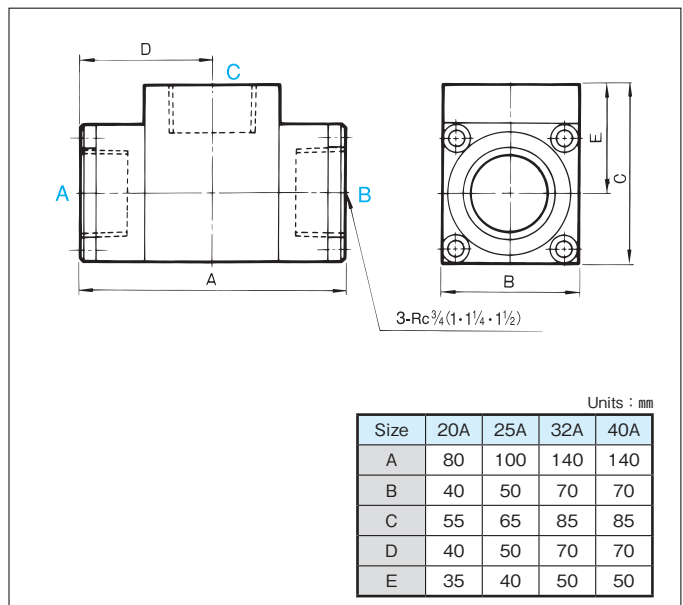

Performance Tables

● Performance more than Rc1_1/4, contact us.

Flow characteristics graphs

Standard type

CVT3-04-8A

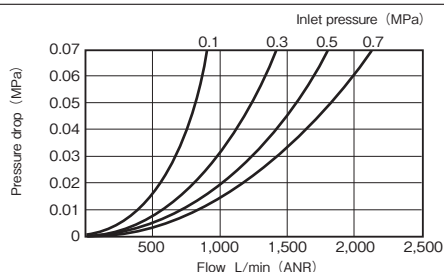

CVT3-04-10A

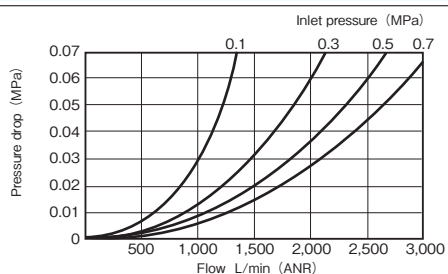

CVT3-04-15A

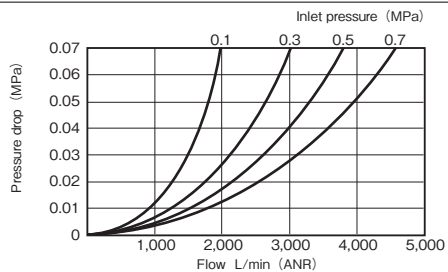

CVT3-06-20A

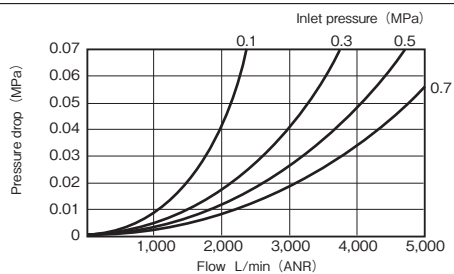

CVT3-08-25A

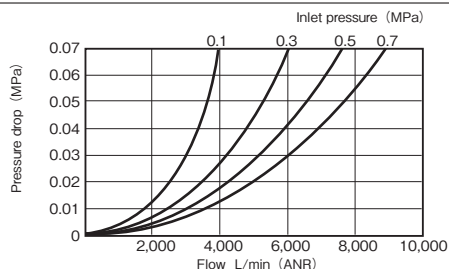

Operating Instructions

1 Varying pressures

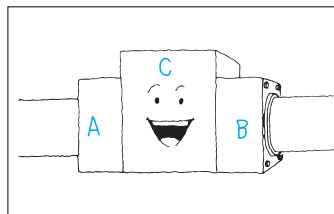

- Take care that ports A and B are level.

2 Fluid

- Use only with clean fluids, as dirt, wastes, etc. in the fluid may cause malfunctioning.

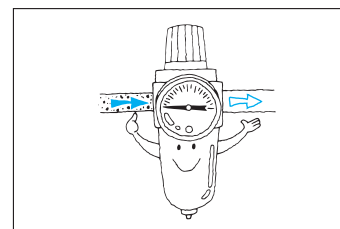

3 Piping

- Take care not to confuse the ports :

- A..... Supply port
- B..... Supply port
- C..... Discharge port

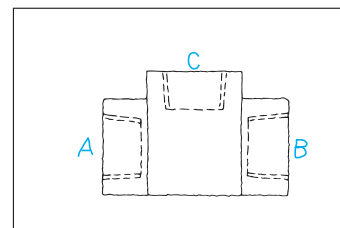

QUICK-RELEASE VALVES

QEV3·QEV3S

Standard type

Rc 1/4 ~ 1

The quick-release valve is installed between directional control valves and actuators such as cylinders, and is operated by the discharge action of the directional control valve. It is used to further increase the discharge volume of the actuator for greater operating speed (up to 1.4 times).

JIS Symbol

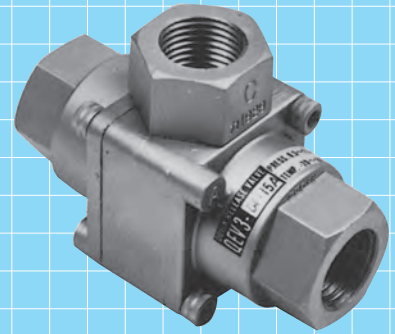
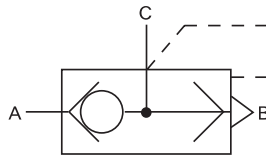

Model Code

When ordering, specify the model as follows:

Standard type

QEV3 **1** -04- **2**

• Corrosion-resistant

• Port size

QEV3 **1** -06-20A- **3**

• Corrosion-resistant

• Operating temperature range

QEV3 **1** -08-25A- **3**

• Corrosion-resistant

• Operating temperature range

1 Corrosion-resistant

- Portions that are exposed to outside weather conditions are corrosion-resistant coating and the exposed bolts and nuts are stainless steel.

Standard	No entry
Corrosion-resistant type	S

2 Port size

Rc 1/4	8A
Rc 3/8	10A
Rc 1/2	15A

3 Operating temperature range

General purpose	-20 ~ 60°C	No entry
Heat-resistant	5 ~ 100°C	HT
Freeze-resistant	-40 ~ 45°C	LT

- For corrosion, freeze resistant type, allow some margin for delivery.
- In operating temperatures of 5°C or less, provide adequate measures against freezing.

Specifications

Model code		QEV3-04			QEV3-06	QEV3-08						
Port size		8A	10A	15A	20A	25A						
		Rc1/4	Rc3/8	Rc1/2	Rc3/4	Rc1						
Effective sectional area	A → C	36mm ²	59mm ²	72mm ²	133mm ²	193mm ²						
	C → B	57mm ²	81mm ²	95mm ²	150mm ²	224mm ²						
Operating pressure		0.05 ~ 0.7MPa										
Proof pressure		1.05MPa										
Operating temperature		-20 ~ 60°C			<table border="1"> <tr> <td>General purpose</td> <td>-20 ~ 60°C</td> </tr> <tr> <td>Heat-resistant</td> <td>5 ~ 100°C</td> </tr> <tr> <td>Freeze-resistant</td> <td>-40 ~ 45°C</td> </tr> </table>		General purpose	-20 ~ 60°C	Heat-resistant	5 ~ 100°C	Freeze-resistant	-40 ~ 45°C
General purpose	-20 ~ 60°C											
Heat-resistant	5 ~ 100°C											
Freeze-resistant	-40 ~ 45°C											
Mass		0.22kg			0.4kg	0.7kg						

- For specifications other than those listed above, please contact us.
- In the event of use in high dry air above dew point - 40°C, please contact us.

Operation

Standard type QEV3 – 04 – 15A

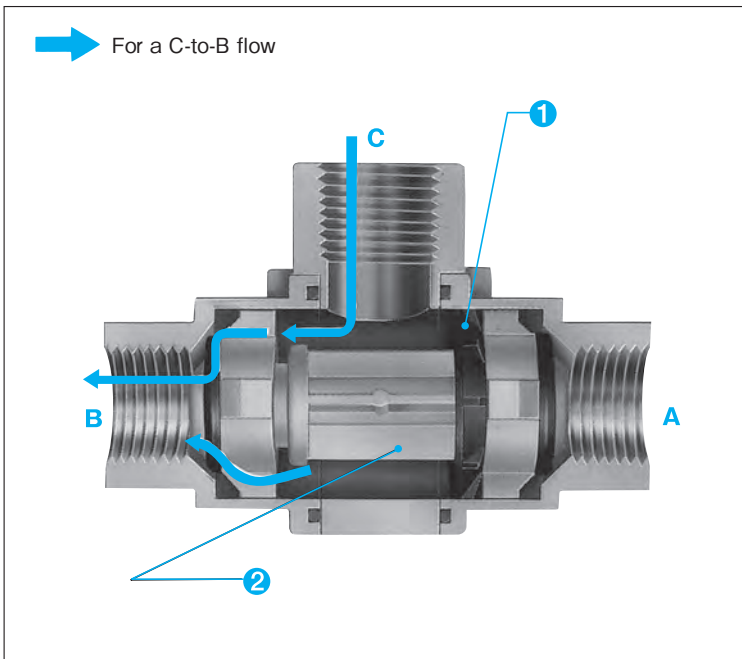

1 Back packing

Air entering port A forces the back packing open and flows to port C. When the air from port A is discharged, air from port C closes the back packing and flows to port B.

2 Valve

With an air pressure from port A, the valve is moved, closing port B, and the air flows to port C. When an pressure from port A is discharged through a directional control valve, the air pressure from port C pushes the back packing and moves the valve to port A. As a result, the air pressure from port C is quickly discharged through port B.

Outside Dimensions

QEV3-04-8A · 10A · 15A

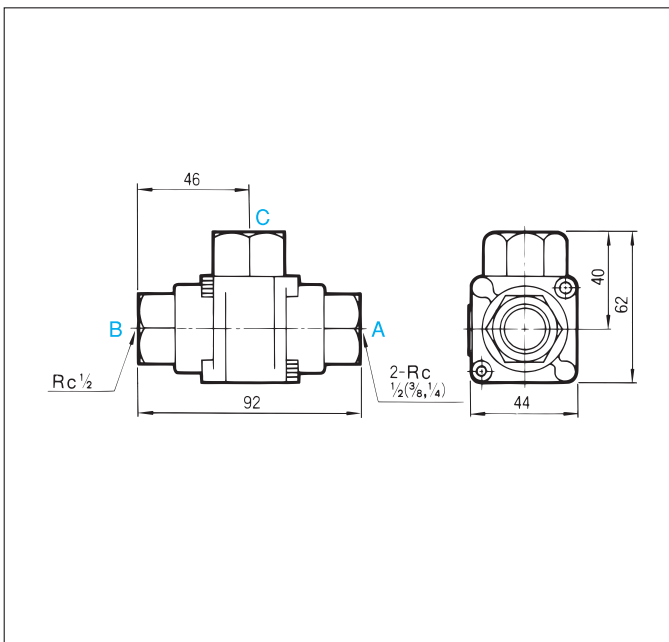

QEV3-06-20A QEV3-08-25A

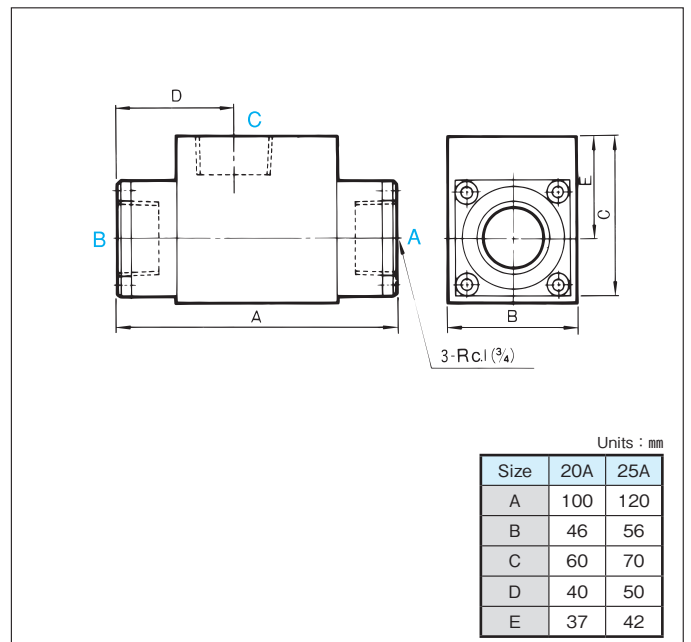

Units : mm

Size	20A	25A
A	100	120
B	46	56
C	60	70
D	40	50
E	37	42

Performance Tables

Flow characteristics graphs (from ports A to C)

QEV3-04-8A

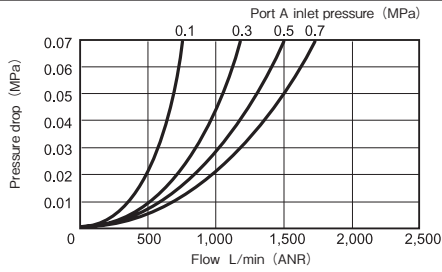

QEV3-04-8A

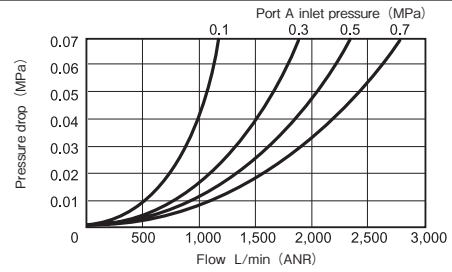

QEV3-04-10A

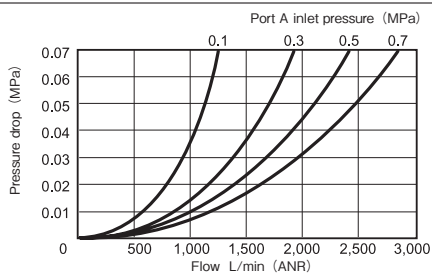

QEV3-04-10A

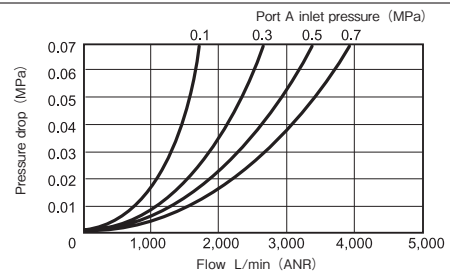

QEV3-04-15A

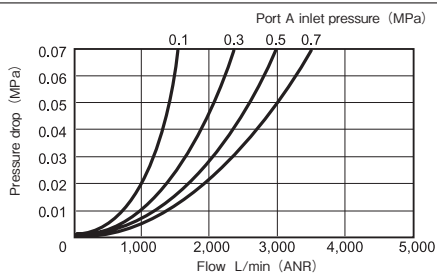

QEV3-04-15A

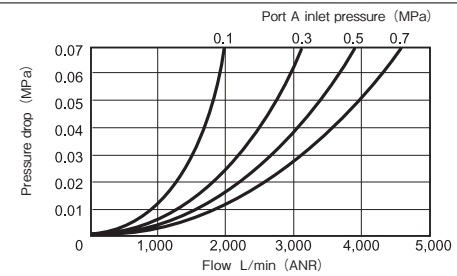

QEV3-06-20A

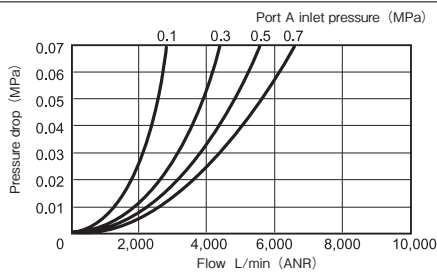

QEV3-06-20A

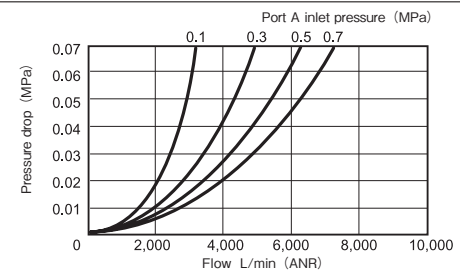

QEV3-08-25A

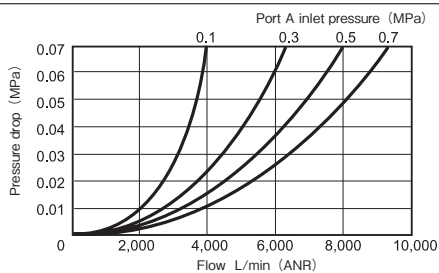

QEV3-08-25A

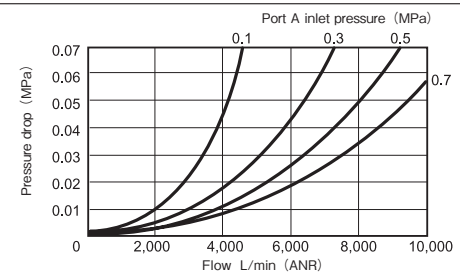

Operating Instructions

1 Installation

- Install as near to the actuator as possible.
- Use piping of as large a diameter as possible for the discharge pipe of the actuator.

2 Fluid

- Use only with clean fluids as dirt, wastes, etc. in the fluid may cause malfunctioning.

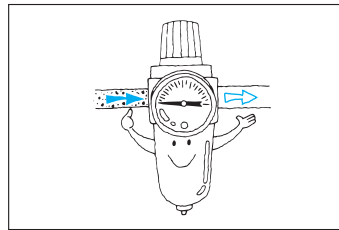

3 Piping

- Take care not to confuse the piping ports :

- A..... For supply
- B..... For discharge
- C..... For actuator

